

CAD FILE:

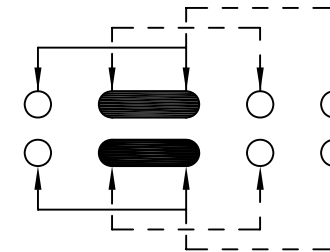

**SCHEMATIC (SHORTING)**

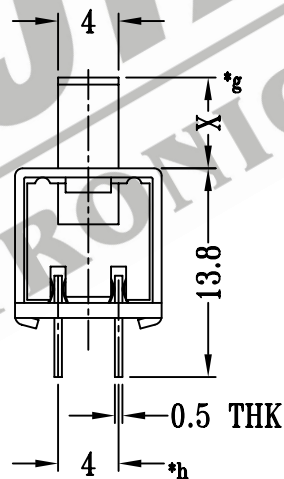
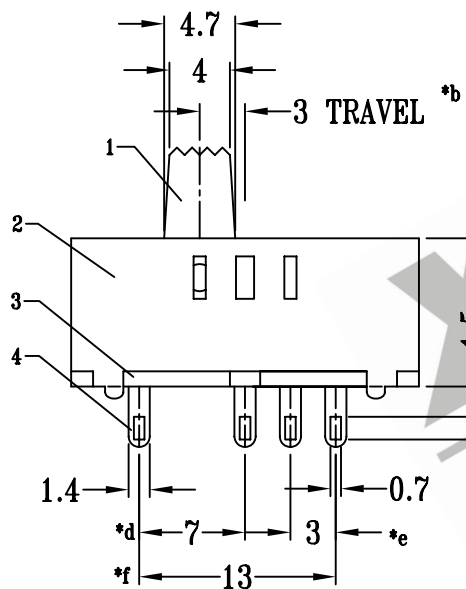
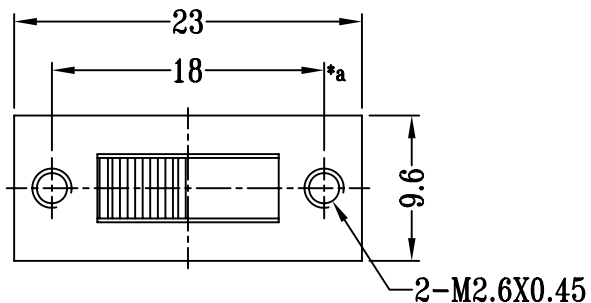
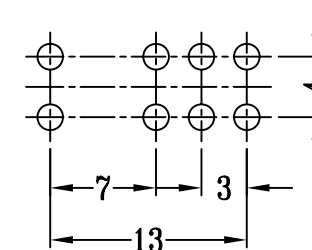

**P.C.B LAYOUT**

注:带"\*"表示关键尺寸(8个)

NO.	PARTS	MATERIALS	Q'TY	FINISH	TOLERANCE UNLESS SPECIFIED	SHENZHEN XIEJIA ELECTRONICS CO.,LTD.				
8						ISSUE	DATE	DESCRIPTIONS OF REVISION		APPD.
7	STEEL BALL	STEEL	1	NATURAL	WITHIN: 1.5±0.1mm OVER : 1.5±0.2mm					
6	SPRING	STEEL WIRE	1	TEMPER						
5	CONTACT CLIP	PBS	2	Ag CLAD						
4	TERMINAL	BRASS STRIP	8	Ag PLATED OVER Ni PLATED	TITLE : VERTICAL SLIDE SWITCH	UNIT : mm	DRWG NO : XJ-DR-SS23F09-00			
3	BASE	PHENOLIC RESIN	1	NATURAL	MODEL: SS-23F09	SCALE: 2:1	DWN.	ZHOUYU	2002-12-30	
2	FRAME	STEEL STRIP	1	Zn PLATED			CHK'D	FANGYING	2002-12-30	
1	KNOB	POM	1	BLACK	ALL MATERIALS MUST BE COMPLIANT TO ROHS		APPD.	KANGXINAN	2002-12-30	